

CMC14

DC Motor Controller | variable speed

Maximum load	10 A / 24 V
Outputs	
Type	⚡ Mosfet H bridge
Nominal switching current	10 A
Inrush current	20 A / max. 3 s
Nominal voltage	24 V
Switching power DC-5	240 W
Power supply	
Nominal operating voltage (DC)	12 – 24 V
Operating voltage (DC)	8 – 28 V
Max. current consumption without load	10 mA
Max. power consumption	DC
12 V	≤ 150 mW
24 V	≤ 300 mW
Time response	
Start ramp	0 – 4 s
Breaking ramp	0 – 4 s
Specifications	
Ambient temperature storage/operation	-40 ... 85°C / -25 ... +60°C (no ice)
Connection terminals	Screw terminal 2.5 mm ²
DC voltage endurance at rated load	> 100 000 h (at 25 °C)
Protection degree	IP 20
Mounting	TS-35 or Back Panel Mounting
Housing material	Aluminium
Weight	80 g

Product References

DC 12-24 CMC14/DC12-24V

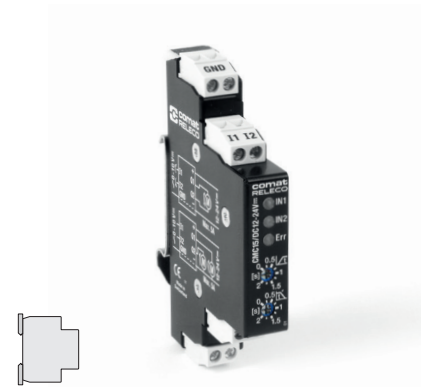

Connection diagram

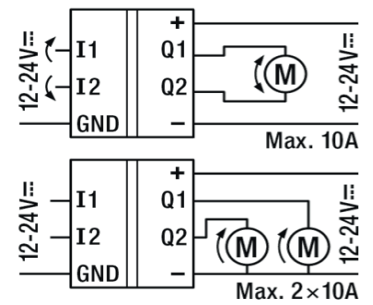

Function diagram

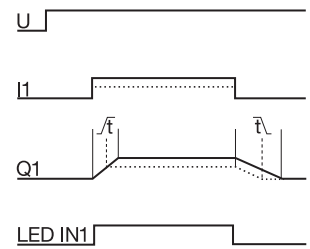

Dimensions (mm)

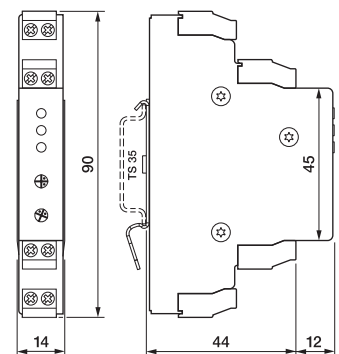

Technical approvals, conformities



IEC/EN 61373